

G/L TYPE STAINLESS STEEL SAFETY VALVE WITH CLAMP FITTING

FEATURES

The G/L type safety valve with clamp fitting is a device designed to protect steam installations against possible overpressures. They operate automatically and close when pressure conditions return to normal. The G/L safety valve is a stainless steel spring safety valve with channelled exhaust, offset holes with test device. As a standard, it is delivered with lead-sealed, with a PTFE leak-sealing. G/L safety valves are TÜV-certified, and are approved as category IV according to the D.E.S.P. directive. 2014/68 can be used for steam, gases and compatible liquids. Clamp connections at the inlet and outlet. Calibration certificate and manufacturer dossier according to the decree of the 20th of November 2017 concerning the monitoring of safety valves, upon simple request.



LIMITS OF USE

Type	G10/L	G14/L	G20/L	G25/L	G40/L
Fluid WP (bar):	30	60	60	60	14
Fluid WT (°C):	PTFE seat 10 bar / +180°C under saturated steam (2863 CL-SS)				

Information given as an indication only, and subject to possible modifications

	SECTORIEL S.A. 45 rue du Ruisseau 38290 SAINT QUENTIN-FALLAVIER – FRANCE Telephone: +33 4 74 94 90 70 - Fax: +33 4 74 94 13 95 www.sectoriel.com / Email : sectoriel@sectoriel.fr	Pages	1/9
		Ref.	FT2863CL ENG
		Rev.	02
		Date	09/2023

G/L TYPE STAINLESS STEEL SAFETY VALVE WITH CLAMP FITTING

HYDRAULIC FEATURES

Type	G10/L	G14/L
Inlet DN	20 or 25	20 or 25
Outlet DN	25	40
Do orifice (mm)	10	13.5
Flow-rate coefficient	0.85	0.81 > 3 bar 0.86
ASME VIII flow-rate coefficient	0.85	0.629
CRN flow-rate coefficient	0.629	0.629
Calibration minimum (bar)	0.3	0.3
Calibration maximum (bar)	30	60

Type	G20/L	G25/L	G40/L
Inlet DN	40	40	50
Outlet DN	40	40	50
Do orifice (mm)	20	25	40
Flow-rate coefficient	0.83	0.78	0.61 > 3 bar 0.71
ASME VIII flow-rate coefficient	0.629	0.629	0.629
CRN flow-rate coefficient	0.629	0.629	0.629
Calibration minimum (bar)	0.3	0.3	0.3
Calibration maximum (bar)	60	60	14

Information given as an indication only, and subject to possible modifications

	SECTORIEL S.A. 45 rue du Ruisseau 38290 SAINT QUENTIN-FALLAVIER – FRANCE Telephone: +33 4 74 94 90 70 - Fax: +33 4 74 94 13 95 www.sectoriel.com / Email : sectoriel@sectoriel.fr	Pages	2/9
		Ref.	FT2863CL ENG
		Rev.	02
		Date	09/2023

G/L TYPE STAINLESS STEEL SAFETY VALVE WITH CLAMP FITTING

DIRECTIVES AND MANUFACTURING STANDARDS

OBJECT	Standard	O.N.
Pressure Equipment Directive 2014/68/EC	Category IV	CE 0036
Directive ATEX 2014/34	Ex II 2G/D c	
EN Construction standard	ISO 4126-1	
US Construction standard	ASME VIII Division 1	
Approval for Canada	CRN	
Approval for Russia	GOST-R	
Inlet and outlet connection	BS 4825 / ASME-BPE1997	

CONSTRUCTION

No.	Name	Material
1	Body (clamp fitting)	1.4401 forged stainless steel
2	Bonnet	AISI 316 forged stainless steel
3	Disc	AISI 316 forged stainless steel
4	Needle	AISI 316 forged stainless steel
5	Stem	AISI 316 forged stainless steel
6	Adjustment screw	AISI 316 forged stainless steel
7	Cap	AISI 316 forged stainless steel
8	Lever	AISI 316 forged stainless steel
9	Spring	AISI 302 SS
10	Seat	PTFE
11	Plate	AISI 316 forged stainless steel
12	Pin	AISI 316 forged stainless steel
13	Clamp fitting	1.4401 forged stainless steel

Name	Stainless steel version (kg)
G10/L	1.0
G14/L	1.0
G20/L	4.0
G25/L	4.0
G40/L	6.8

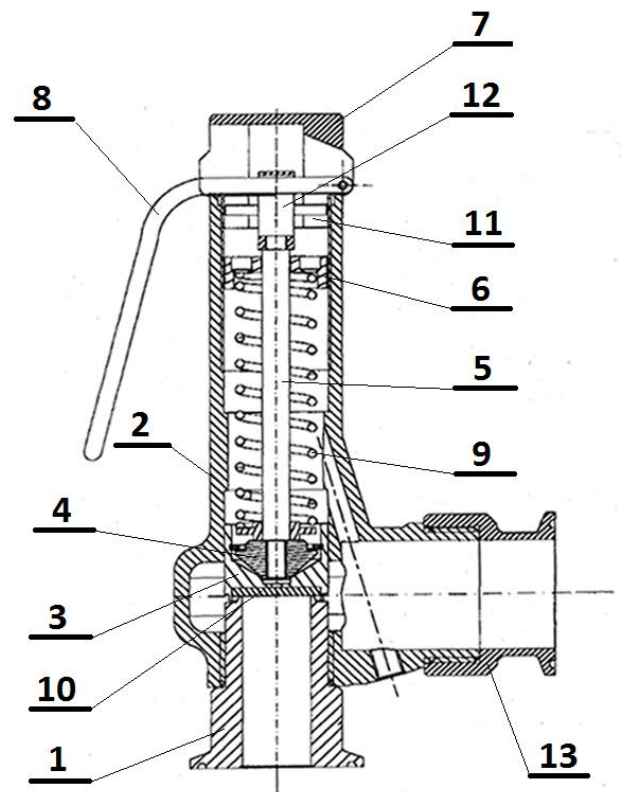

Information given as an indication only, and subject to possible modifications



SECTORIEL S.A.
 45 rue du Ruisseau
 38290 SAINT QUENTIN-FALLAVIER – FRANCE
 Telephone: +33 4 74 94 90 70 - Fax: +33 4 74 94 13 95
www.sectoriel.com / Email : sectoriel@sectoriel.fr

Pages	3/9
Ref.	FT2863CL ENG
Rev.	02
Date	09/2023

G/L TYPE STAINLESS STEEL SAFETY VALVE WITH CLAMP FITTING

DIMENSIONS (mm)

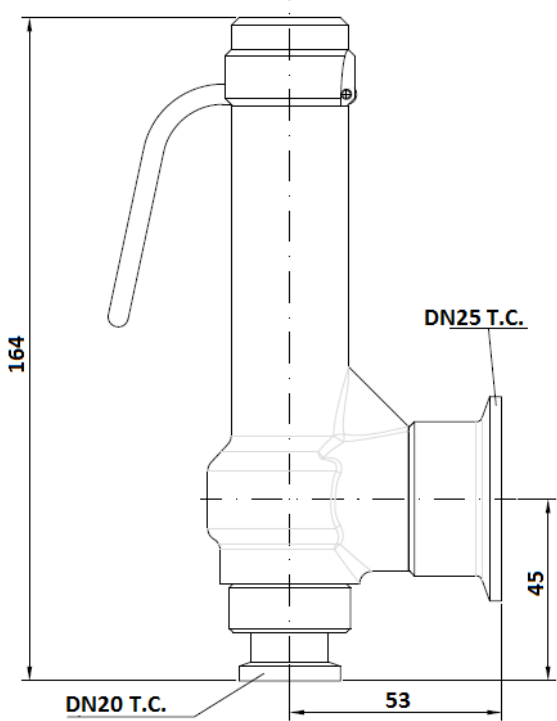
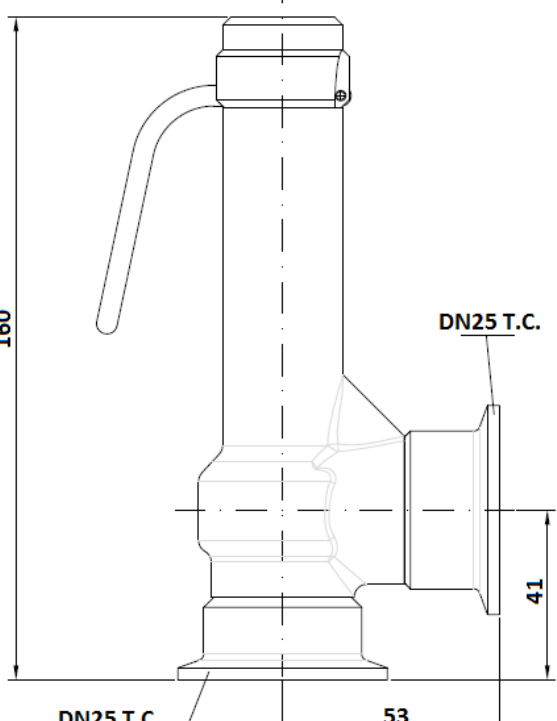
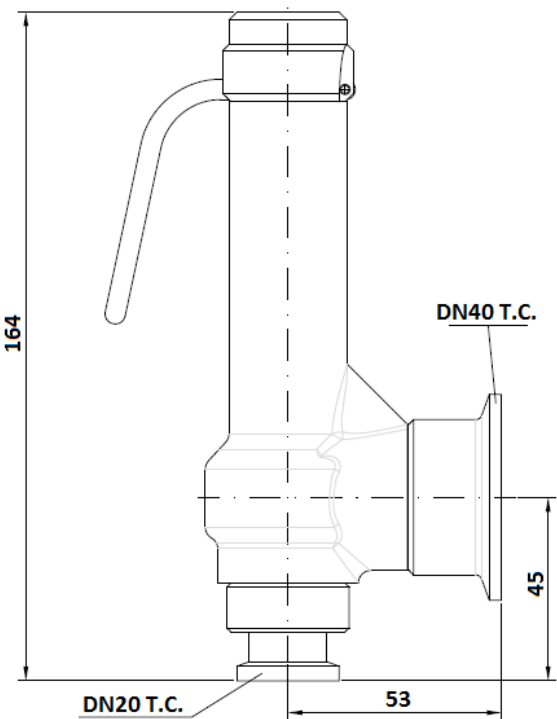
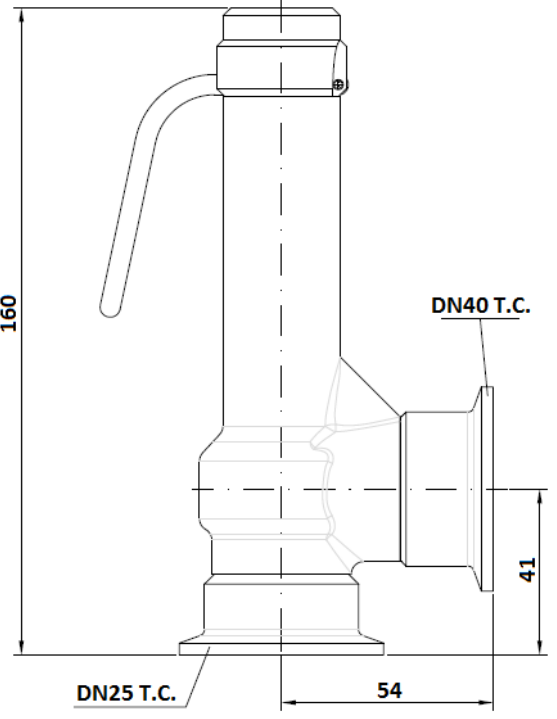
G10/L (Ferrule $\varnothing 25 \times \varnothing 50.5$)	G10/L (Ferrule $\varnothing 50.5 \times \varnothing 50.5$)
 <p>Technical drawing of G10/L safety valve with ferrule dimensions: total height 164mm, DN20 T.C. inlet, 53mm inlet diameter, DN25 T.C. outlet, 45mm outlet diameter.</p>	 <p>Technical drawing of G10/L safety valve with ferrule dimensions: total height 160mm, DN25 T.C. inlet, 53mm inlet diameter, DN25 T.C. outlet, 41mm outlet diameter.</p>
G14/L (Ferrule $\varnothing 25 \times \varnothing 50.5$)	G14/L (Ferrule $\varnothing 50.5 \times \varnothing 50.5$)
 <p>Technical drawing of G14/L safety valve with ferrule dimensions: total height 164mm, DN20 T.C. inlet, 53mm inlet diameter, DN40 T.C. outlet, 45mm outlet diameter.</p>	 <p>Technical drawing of G14/L safety valve with ferrule dimensions: total height 160mm, DN25 T.C. inlet, 54mm inlet diameter, DN40 T.C. outlet, 41mm outlet diameter.</p>

Information given as an indication only, and subject to possible modifications



SECTORIEL S.A.
 45 rue du Ruisseau
 38290 SAINT QUENTIN-FALLAVIER – FRANCE
 Telephone: +33 4 74 94 90 70 - Fax: +33 4 74 94 13 95
www.sectoriel.com / Email : sectoriel@sectoriel.fr

Pages	4/9
Ref.	FT2863CL ENG
Rev.	02
Date	09/2023

G/L TYPE STAINLESS STEEL SAFETY VALVE WITH CLAMP FITTING

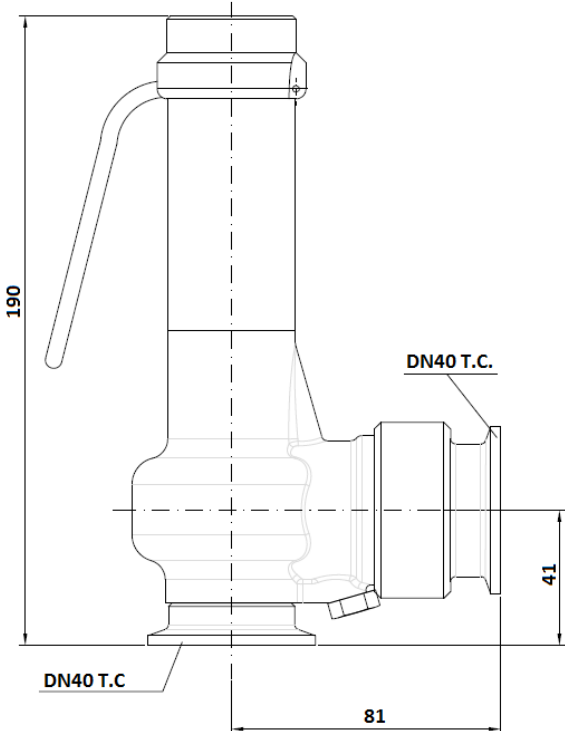
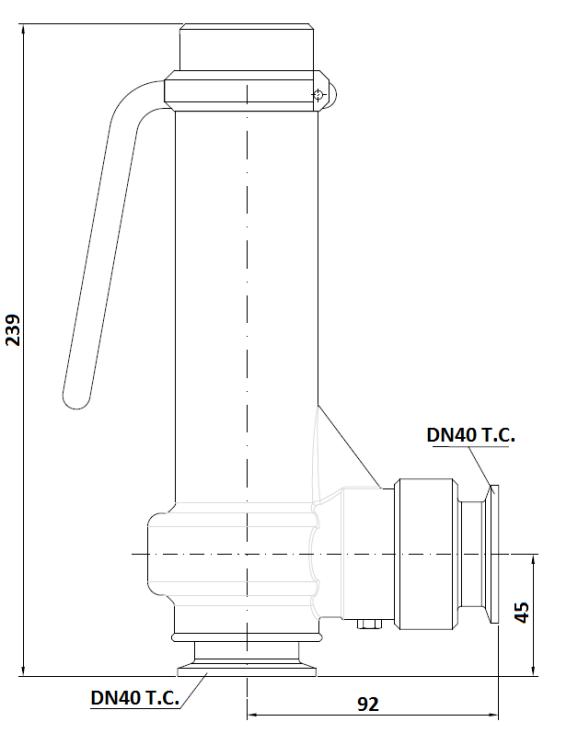
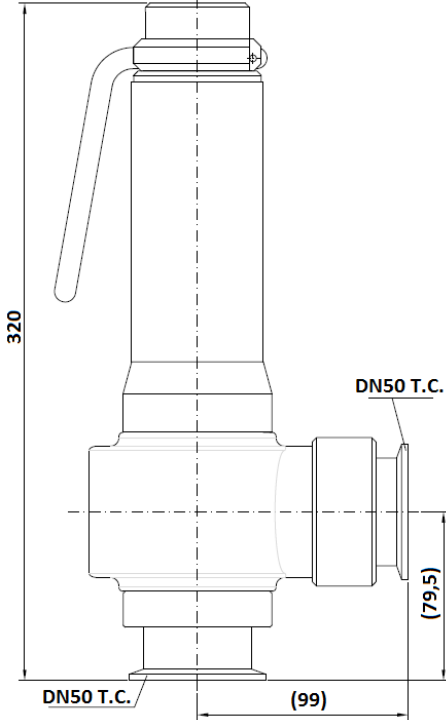
G20/L (Ferrule $\varnothing 50.5 \times \varnothing 50.5$)	G25/L (Ferrule $\varnothing 50.5 \times \varnothing 50.5$)
 <p>Technical drawing of the G20/L safety valve. The drawing shows a side view of the valve with a handle on the left. Dimensions are indicated: a total height of 190, a base diameter of DN40 T.C., a main body diameter of DN40 T.C., and a bottom flange diameter of 81. A side connection is labeled DN40 T.C. with a diameter of 41.</p>	 <p>Technical drawing of the G25/L safety valve. The drawing shows a side view of the valve with a handle on the left. Dimensions are indicated: a total height of 239, a base diameter of DN40 T.C., a main body diameter of DN40 T.C., and a bottom flange diameter of 92. A side connection is labeled DN40 T.C. with a diameter of 45.</p>
G40/L (Ferrule $\varnothing 64 \times \varnothing 64$)	
 <p>Technical drawing of the G40/L safety valve. The drawing shows a side view of the valve with a handle on the left. Dimensions are indicated: a total height of 320, a base diameter of DN50 T.C., a main body diameter of DN50 T.C., and a bottom flange diameter of (99). A side connection is labeled DN50 T.C. with a diameter of (79,5).</p>	

Information given as an indication only, and subject to possible modifications



SECTORIEL S.A.
 45 rue du Ruisseau
 38290 SAINT QUENTIN-FALLAVIER – FRANCE
 Telephone: +33 4 74 94 90 70 - Fax: +33 4 74 94 13 95
www.sectoriel.com / Email : sectoriel@sectoriel.fr

Pages	5/9
Ref.	FT2863CL ENG
Rev.	02
Date	09/2023

G/L TYPE STAINLESS STEEL SAFETY VALVE WITH CLAMP FITTING

INSTALLATION

The safety valve has to be positioned as close as possible to the volume to protect. It must always be installed, in the vertical position. No valve must be installed in-between the volume to protect and the safety valve. No foreign body must block the discharge orifice of the safety valve. The exhaust has to be connected to piping without counter-pressure, discharging into a hazard free location. The safety valve must not support the exhaust piping. The safety valve installation and servicing have to be carried out according to state-of-the-art rules, following the instruction leaflet provided with the safety valve.

STEAM FLOW-RATE IN kg/h

According to the ISO 4126-7 standard

Type	G10/L	G14/L	G20/L	G25/L	G40/L	Type	G10/L	G14/L	G20/L	G25/L	G40/L
P (bar)	kg/h					P (bar)	kg/h				
1	67	133	327	438	815	21	743	1512	3513	-	-
2	104	209	497	666	1340	22	777	1581	3674	-	-
3	139	283	657	880	1849	23	809	1646	3824	-	-
4	174	353	821	1099	2310	24	841	1710	3974	-	-
5	208	423	983	1316	2766	25	874	1779	4134	-	-
6	241	489	1137	1523	3200	26	-	1848	4293	-	-
7	275	560	1302	1743	3663	27	-	1916	4453	-	-
8	309	628	1458	1953	4105	28	-	1985	4612	-	-
9	343	698	1622	2172	4566	29	-	2054	4772	-	-
10	376	765	1777	2379	5000	30	-	2122	4932	-	-
11	410	835	1939	2597	5459	31	-	2191	5091	-	-
12	442	900	2091	2801	5887	32	-	2260	5251	-	-
13	477	970	2254	3018	6343	33	-	2329	5410	-	-
14	511	1040	2416	3235	6799	34	-	2397	5570	-	-
15	544	1107	2571	3443	-	35	-	2466	5729	-	-
16	578	1176	2733	3659	-	36	-	2535	5889	-	-
17	611	1242	2887	3866	-	37	-	2603	6048	-	-
18	645	1312	3048	4082	-	38	-	2672	6208	-	-
19	677	1378	3201	4287	-	39	-	2741	6368	-	-
20	711	1447	3362	4502	-	40	-	2809	6527	-	-

Information given as an indication only, and subject to possible modifications

	SECTORIEL S.A. 45 rue du Ruisseau 38290 SAINT QUENTIN-FALLAVIER – FRANCE Telephone: +33 4 74 94 90 70 - Fax: +33 4 74 94 13 95 www.sectoriel.com / Email : sectoriel@sectoriel.fr	Pages	6/9
		Ref.	FT2863CL ENG
		Rev.	02
		Date	09/2023

G/L TYPE STAINLESS STEEL SAFETY VALVE WITH CLAMP FITTING

INSTALLATION AND SERVICING REGULATION

1 - DESCRIPTION

1.1 NGI spring safety valves are designed for steam, gas, and liquids. They are the result of tens of years of experience on many applications, and widely provide their function of ultimate of pressure devices. They are able to guarantee that the internal pressure does not exceed the authorised maximum, even if other safety systems installed upstream are faulty, insofar as they have been sized correctly.

1.2 NGI safety valves are made of brass or stainless steel. All safety valves are calibrated and lead sealed at the factory, for maximum safety and minimum maintenance.

2 - GUARANTEE

2.1 Before any contact with our services, please identify the type of safety valve and the individual number engraved on the safety valve body.

2.2 NGI safety valves have a 24-month guarantee, as of the delivery date. Parts admitted as faulty by an assessment at our factory, will be replaced at our expense. Complaints resulting from the incorrect use, modification of the safety valve, a leak following the passage of impurities, shall not be accepted.

3 - TRANSPORT, INSPECTION AT ACCEPTANCE AND STORAGE

3.1 CAUTION: The safety valve can be damaged by vibrations, impacts and the contact with impurities. For this reason, the safety valve has to be handled with precaution, without removing the protective plugs before installation, and without manoeuvring the test lever.

3.2 At acceptance, check that:

- the packaging is in good condition,
- the delivered safety valve is as ordered,
- the equipment has not been damaged,
- the safety valve is delivered with a calibration certificate whose number must match that engraved on the safety valve body.

3.3 It is recommended to install the safety valve as of acceptance and not to leave it unused. If the equipment has to be stored, it must be in a dry place protected from the weather.

4 - PRECAUTIONS FOR OPERATION

4.1 Before installing, make sure that the installation is completely depressurized and brought to ambient temperature.

4.2 Any adjustment or any modification can only be made by technicians qualified for safety valves.

4.3 CAUTION WITH TOXIC GASES

If the safety valve is installed on an acid tank, wear gloves and safety glasses, and any other personal protection needed.

4.4 The safety valve cannot be commissioned unless it has been calibrated, lead sealed and certified by NGI. The calibration certificate bears the indication of the exact pressure of its calibration.

Information given as an indication only, and subject to possible modifications

	SECTORIEL S.A. 45 rue du Ruisseau 38290 SAINT QUENTIN-FALLAVIER – FRANCE Telephone: +33 4 74 94 90 70 - Fax: +33 4 74 94 13 95 www.sectoriel.com / Email : sectoriel@sectoriel.fr	Pages	7/9
		Ref.	FT2863CL ENG
		Rev.	02
		Date	09/2023

G/L TYPE STAINLESS STEEL SAFETY VALVE WITH CLAMP FITTING

4.5 When a safety valve with free exhaust in operation, has to be tested, make sure beforehand that nobody stays in the way of the exhaust. Do not let toxic, explosive or flammable products discharge into the atmosphere. Before testing, schedule a controlled degassing procedure in a confined volume.

4.6 Do not perform work on the safety valve, do not break its lead seal, and do not modify its calibration pressure.

4.7 Do not subject the safety valve to a hot or cold shock.

4.8 In case of malfunctioning, contact SECTORIEL or NGI immediately.

4.9 CAUTION: ONLY STAINLESS STEEL SAFETY VALVES MUST BE INSTALLED IN A CORROSIVE ENVIRONMENT.

4.10 The type of connection has to match the piping class of the installation.

4.11 We recommend to choose, preferably, a channelled exhaust safety valve. If the safety valve discharges directly into the atmosphere, direct the exhaust so as not to cause any damage to equipment or persons. Upon request, it is possible to provide a safety valve with a leak detector for the control and instrumentation.

5 - INSTALLATION

5.1 Check that the lead seal has not been damaged.

Spring safety valves have to be installed in the vertical position with the bonnet upwards.

5.3 Be careful not to damage the seats, remove the protective plugs and install the safety valve on the installation according to its type of connection.

5.4 No isolation valve shall be placed in-between the volume to protect and the safety valve.

5.5 No reduction limiting the flow-rate to discharge shall be placed in-between the volume to protect and the safety valve.

5.6 For channelled exhaust safety valves, make sure that the discharge piping discharges into a location free of hazards for personnel and the environment.

5.7 If the safety valve exhaust has to be connected to a piping, make sure that the latter is as short as possible so as to create just a minimum counter-pressure.

5.8 The piping connected to a channelled exhaust safety valve should not be supported by the safety valve itself. Otherwise, leaks may occur.

6 - CLEANING AND LUBRICATION

6.1 NGI safety valves are designed not to require any lubrication.

6.2 Keep the safety valve clean and in running order. Check, in particular, that the exhaust stays clear and that no foreign body blocks the discharge piping.

7 - USUAL MAINTENANCE

7.1 The safety valve is a sensitive safety element which has to be checked periodically. In case of reported malfunctioning, please contact SECTORIEL or NGI.

7.2 CAUTION: NGI and SECTORIEL are no longer responsible for the proper operation of a safety valve which has been disassembled, modified or re-calibrated by a person not authorised by NGI or SECTORIEL.

Information given as an indication only, and subject to possible modifications

	SECTORIEL S.A. 45 rue du Ruisseau 38290 SAINT QUENTIN-FALLAVIER – FRANCE Telephone: +33 4 74 94 90 70 - Fax: +33 4 74 94 13 95 www.sectoriel.com / Email : sectoriel@sectoriel.fr	Pages	8/9
		Ref.	FT2863CL ENG
		Rev.	02
		Date	09/2023

G/L TYPE STAINLESS STEEL SAFETY VALVE WITH CLAMP FITTING

8 - PERIODIC INSPECTION

8.1 To make sure that the safety valve is still operating, it has to be tested periodically. To carry out this test, the lever or the test thumb screw have to be manually actuated, briefly. To protect the installation during this test, the test pressure must stay between 80 and 90% of the calibration pressure. The safety valve has to be wide open to allow a significant flow-rate to circulate.

At re-closing, make sure that the seat is again leak-tight. At the start of an installation, it is recommended to carry this test regularly.

8.2 For use on gas or steam on installations located on the French territory, comply with the prescriptions of the order of 20th November 2017 concerning the monitoring of safety valves.

Information given as an indication only, and subject to possible modifications

	SECTORIEL S.A. 45 rue du Ruisseau 38290 SAINT QUENTIN-FALLAVIER – FRANCE Telephone: +33 4 74 94 90 70 - Fax: +33 4 74 94 13 95 www.sectoriel.com / Email : sectoriel@sectoriel.fr	Pages	9/9
		Ref.	FT2863CL ENG
		Rev.	02
		Date	09/2023